

# Keysight E4982A LCR Meter



NOTICE: This document contains references to Agilent Technologies. Agilent's former Test and Measurement business has become Keysight Technologies. For more information, go to [www.keysight.com](http://www.keysight.com).



# Notices

© Keysight Technologies 2012, 2015

No part of this manual may be reproduced in any form or by any means (including electronic storage and retrieval or translation into a foreign language) without prior agreement and written consent from Keysight Technologies as governed by United States and international copyright laws.

## Manual Printing History

The manual's printing date and part number indicate its current edition. The printing date changes when a new edition is printed (minor corrections and updates that are incorporated at reprint do not cause the date to change). The manual part number changes when extensive technical changes are incorporated.

February 2012 Edition 1  
February 2015 Edition 2

## Manual Part Number

E4982-90000

## Edition

Edition 2, February 2015

Printed in Malaysia

Keysight Technologies  
1400 Fountaingrove Parkway  
Santa Rosa, CA 95403 USA

## Warranty

**The material contained in this document is provided "as is," and is subject to being changed, without notice, in future editions. Further, to the maximum extent permitted by applicable law, Keysight disclaims all warranties, either express or implied, with regard to this manual and any information contained herein, including but not limited to the implied warranties of merchantability and fitness for a particular purpose. Keysight shall not be liable for errors or for incidental or consequential damages in connection with the furnishing, use, or performance of this document or of any information contained herein. Should Keysight and the user have a separate written agreement with warranty terms covering the material in this document that conflict with these terms, the warranty terms in the separate agreement shall control.**

## Technology Licenses

The hardware and/or software described in this document are furnished under a license and may be used or copied only in accordance with the terms of such license

## Restricted Rights Legend

If software is for use in the performance of a U.S. Government prime contract or subcontract, Software is delivered and licensed as "Commercial computer soft-

ware" as defined in DFAR 252.227-7014 (June 1995), or as a "commercial item" as defined in FAR 2.101(a) or as "Restricted computer software" as defined in FAR 52.227-19 (June 1987) or any equivalent agency regulation or contract clause. Use, duplication or disclosure of Software is subject to Keysight Technologies' standard commercial license terms, and non-DOD Departments and Agencies of the U.S. Government will receive no greater than Restricted Rights as defined in FAR 52.227-19(c)(1-2) (June 1987). U.S. Government users will receive no greater than Limited Rights as defined in FAR 52.227-14 (June 1987) or DFAR 252.227-7015 (b)(2) (November 1995), as applicable in any technical data.

## Safety Notices

### CAUTION

A **CAUTION** notice denotes a hazard. It calls attention to an operating procedure, practice, or the like that, if not correctly performed or adhered to, could result in damage to the product or loss of important data. Do not proceed beyond a **CAUTION** notice until the indicated conditions are fully understood and met.

### WARNING

A **WARNING** notice denotes a hazard. It calls attention to an operating procedure, practice, or the like that, if not correctly performed or adhered to, could result in personal injury or death. Do not proceed beyond a **WARNING** notice until the indicated conditions are fully understood and met.

## Caution



Do not exceed the operating input power, voltage, and current level and signal type appropriate for the instrument being used, refer to your instrument's Function Reference.



Electrostatic discharge (ESD) can damage the highly sensitive microcircuits in your instrument. ESD damage is most likely to occur as the test fixtures are being connected or disconnected. Protect them from ESD damage by wearing a grounding strap that provides a high resistance path to ground. Alternatively, ground yourself to discharge any static charge built-up by touching the outer shell of any grounded instrument chassis before touching the test port connectors.

## Safety Summary

When you notice any of the unusual conditions listed below, immediately terminate operation and disconnect the power cable.

Contact your local Keysight Technologies sales representative or authorized service company for repair of the instrument. If you continue to operate without repairing the instrument, there is a potential fire or shock hazard to the operator.

- Instrument operates abnormally.
- Instrument emits abnormal noise, smell, smoke or a spark-like light during operation.
- Instrument generates high temperature or electrical shock during operation.
- Power cable, plug, or receptacle on instrument is damaged.
- Foreign substance or liquid has fallen into the instrument.

## **Manufacturer's Declaration**

### **Herstellerbescheinigung**

GERA- USCHEMISSION

LpA < 70 dB

am Arbeitsplatz

normaler Betrieb

nach DIN 45635 T. 19

### **Manufacturer's Declaration**

ACOUSTIC NOISE EMISSION

LpA < 70 dB

operator position

normal operation

per ISO 7779

## **Regulatory Compliance Information**

This product complies with the essential requirements of the following applicable European Directives, and carries the CE marking accordingly:

- The Low Voltage Directive 2006/95/EC
- The EMC Directive 2004/108/EEC

To obtain Declaration of Conformity, please contact your local Keysight Technologies sales office, agent or distributor.



## Safety Notice Supplement

- This equipment complies with EN/IEC61010-1:2001.
- This equipment is of MEASUREMENT CATEGORY I (CAT I). Do not use for CAT II, III, or IV.
- Do not connect the measuring terminals to mains.
- This equipment is a POLLUTION DEGREE 2, INDOOR USE product.
- This equipment is tested in stand-alone condition and in combination with the accessories supplied by Keysight Technologies against the requirement of the standards described in the Declaration of Conformity. If it is used as a system component, compliance of related regulations and safety requirements are to be confirmed by the builder of the system.

## General Safety Precautions

The following general safety precautions must be observed during all phases of operation, service, and repair of this instrument. Failure to comply with these precautions or with specific WARNINGS elsewhere in this manual may impair the protection provided by the equipment. Such noncompliance would also violate safety standards of design, manufacture, and intended use of the instrument. Keysight Technologies assumes no liability for the customer's failure to comply with these precautions.

### NOTE

The E4982A complies with INSTALLATION CATEGORY II as well as POLLUTION DEGREE 2 in IEC61010-1. The E4982A is an INDOOR USE product.

---

### NOTE

The LEDs in the E4982A are Class 1 in accordance with IEC60825-1, CLASS 1 LED PRODUCT.

---

- Ground the Instrument

To avoid electric shock, the instrument chassis and cabinet must be grounded with the supplied power cable's grounding prong.

- DO NOT Operate in an Explosive Atmosphere

Do not operate the instrument in the presence of inflammable gasses or fumes. Operation of any electrical instrument in such an environment clearly constitutes a safety hazard.

- Keep Away from Live Circuits

Operators must not remove instrument covers. Component replacement and internal adjustments must be made by qualified maintenance personnel. Do not replace components with the power cable connected. Under certain conditions, dangerous voltage levels may remain even after the power cable has been disconnected. To avoid injuries, always disconnect the power and discharge circuits before touching them.

- DO NOT Service or Adjust the Instrument Alone

Do not attempt internal service or adjustment unless another person, capable of rendering first aid and resuscitation, is present.

- DO NOT Substitute Parts or Modify the Instrument

To avoid the danger of introducing additional hazards, do not install substitute parts or perform unauthorized modifications to the instrument. Return the instrument to a Keysight Technologies Sales and Service Office for service and repair to ensure that safety features are maintained in operational condition.

- Dangerous Procedure Warnings

Warnings, such as the example below, precede potentially dangerous procedures throughout this manual. Instructions contained in the warnings must be followed.









**WARNING**

**Dangerous voltage levels, capable of causing death, are present in this instrument. Use extreme caution when handling, testing, and adjusting this instrument.**

---

# Safety Symbols

General definitions of safety symbols used on the instrument or in manuals are listed below.

-  Instruction Manual symbol: the product is marked with this symbol when it is necessary for the user to refer to the instrument manual.
-  Alternating current.
-  Direct current.
-  On (Supply).
-  Off (Supply).
-  In-position of push-button switch.
-  Out-position of push-button switch.
-  A chassis terminal; a connection to the instrument's chassis, which includes all exposed metal structure.
-  Standby.

## WARNING

This warning sign denotes a hazard. It calls attention to a procedure, practice, or condition that, if not correctly performed or adhered to, could result in injury or death to personnel.

---

## CAUTION

This Caution sign denotes a hazard. It calls attention to a procedure, practice, or condition that, if not correctly performed or adhered to, could result in damage to or destruction of part or all of the instrument.

---

## NOTE

This Note sign denotes important information. It calls attention to a procedure, practice, or condition that is essential for the user to understand.

---

## **Certification**

Keysight Technologies certifies that this product met its published specifications at the time of shipment from the factory. Keysight Technologies further certifies that its calibration measurements are traceable to the United States National Institute of Standards and Technology, to the extent allowed by the Institution's calibration facility or by the calibration facilities of other International Standards Organization members.

## **Documentation Warranty**

The material contained in this document is provided "as is," and is subject to being changed, without notice, in future editions. Further, to the maximum extent permitted by applicable law, Keysight disclaims all warranties, either express or implied with regard to this manual and any information contained herein, including but not limited to the implied warranties of merchantability and fitness for a particular purpose. Keysight shall not be liable for errors or for incidental or consequential damages in connection with the furnishing, use, or performance of this document or any information contained herein. Should Keysight and the user have a separate written agreement with warranty terms covering the material in this document that conflict with these terms, the warranty terms in the separate agreement will control.

## **Exclusive Remedies**

The remedies provided herein are Buyer's sole and exclusive remedies. Keysight Technologies shall not be liable for any direct, indirect, special, incidental, or consequential damages, whether based on contract, tort, or any other legal theory.

## **Assistance**

Product maintenance agreements and other customer assistance agreements are available for Keysight Technologies products.

For any assistance, contact your nearest Keysight Technologies Sales and Service Office. Addresses are provided at the back of this manual.

# Manuals for E4982A

Keysight provides the following three manuals for E4982A. The latest version of all documentations can be downloaded from <http://www.keysight.com/find/e4982a-manual>.

## Installation Guide

The installation guide (this manual) provides start up setup information when you use the E4982A for the first time and troubleshooting information when the Windows cannot be boot up. See this manual first when you use the E4982A for the first time.

## Online Help

The online help provides the information about the quick start, measurement operation, programming, handler interface. This is pre-installed in the E4982A. Press [**Help**] hard key on the front panel to open. Quick Start helps in understanding the E4982A operation quickly.

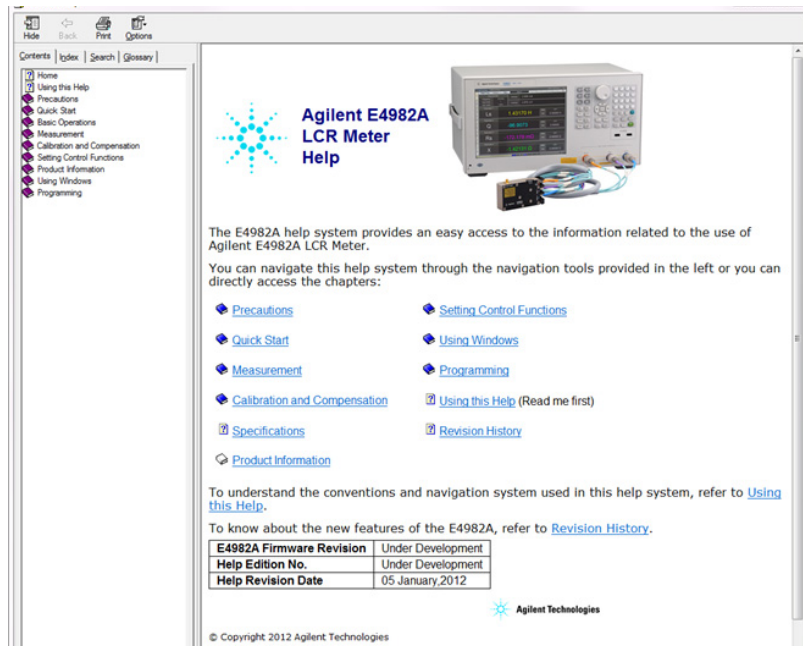

The latest version of online help is available at: <http://ena.support.keysight.com/e4982a/manuals/webhelp/eng>

The online help has context sensitive help, which is a great feature of the E4982A help. It allows you to get information about the selected softkey by pressing the **Help** key in the E4982A or by pressing **F1** in a keyboard attached to the E4982A or by clicking the help button in a dialog box. With

context sensitive help, users can receive information quickly about the area the user is working in the firmware of the E4982A. It provides information relevant to the task that needs to be accomplished and reduces the time to search relevant information required to complete a task.

### **Service Guide**

The service manual provides information about the parts, troubleshooting, performance test, adjustment and service menu.

## In This Guide...

The following shows the contents of this manual.

### **Chapter 1, "Installation"**

This chapter provides information about how to set up the Keysight E4982A.

### **Chapter 2, "Troubleshooting"**

This chapter describes the troubleshooting during start up and the procedure of the operating system (OS) recovery when the Windows XP OS has been damaged.



# Contents

Regulatory Compliance Information	6
Safety Notice Supplement	7
Checking the Shipment	18
Environmental Requirements	20
Operating Environments	20
Ventilation Requirement	20
Protection Against Electrostatic Discharge (ESD)	21
Ensuring Adequate Free Space around Meter for Immediate Disconnection of Power Cable in Case of Emergency	22
Installing Front Handles/Rack Mounting Flanges	23
How to Install the Handle Kit (Option 1CN)	24
How to Install the Rack-mount Kit (Option 1CM)	25
How to Install the Rack-mount and Handle Kit (Option 1CP)	25
Connecting Test Head	27
Connecting the DUT when using a special test fixture	27
When using the test head fixed on a handler, etc.	29
Caution for connecting the SMA connector to the test head connector	30
Connecting Mouse and Keyboard	32
Power Supply	33
Verification of the Power Supply	33
Verification and Connection of Power Cable	33
Blown Fuses	34
Starting the E4982A	35
Turning the Power ON and OFF	35
Disconnection from Supply Source	36
Initial Registration of E4982A	38
Calibration of the Touch Screen	44
Troubleshooting during Startup	48
System Recovery	49

Notes on executing the factory recovery function	49
Procedure to execute the factory recovery	49

# **1 Installation**

Checking the Shipment	18
Environmental Requirements	20
Installing Front Handles/Rack Mounting Flanges	23
Connecting Mouse and Keyboard	32
Power Supply	33
Blown Fuses	34
Starting the E4982A	35
Initial Registration of E4982A	38
Calibration of the Touch Screen	44

This chapter provides information about how to set up the Keysight E4982A.

## Checking the Shipment

After you receive the meter, carry out checks during unpacking according to the following procedure.

### WARNING

**When unpacking the meter, if the exterior of the meter (such as the cover, front/rear panel, LCD screen, power switch, and port connectors) appear to be damaged during transport, do not turn on the power switch. Otherwise, you may get an electric shock.**

---

**Step 1.** Check that the packing box or shock-absorbing material used to package the meter has not been damaged.

### NOTE

If the packing box or shock-absorbing material has been damaged, leave the packing box and shock-absorbing material as is until other inspection items are checked as follows.

---

**Step 2.** Check the packaged items supplied with the meter for any damage or defects.

**Step 3.** By referring to the furnished contents list, check that all packaged items supplied with the meter have been received as per the specified options.

**Step 4.** After checking, if one of the following applies, contact your nearest Keysight Technologies sales and service office.

- 1 The packing box or shock-absorbing material used to package the meter has been damaged or the shock-absorbing material has traces where extreme force has been applied.
- 2 A packaged item supplied with the meter has mechanical damage or defects.
- 3 A packaged item supplied with the meter is missing.
- 4 A fault has been detected in the subsequent operation check of the meter.

If an abnormality is detected in step 1, contact the company that transported the meter as well as your nearest Keysight Technologies sales and service office. For

inspection by the transport company, save the packing box, shock-absorbing material, and packaged items as you received them.

## Environmental Requirements

Set up the E4982A where the following environmental requirements are met.

### Operating Environments

Ensure that the operating environment meets the following requirements.

Temperature	5 °C to 40 °C
Temperature range at the error-correction	23 °C ± 5 °C (< 1 °C deviation from the temperature when performing the error-correction)
Humidity	20% to 80% at wet bulb temperature < +29 °C (non-condensation)
Altitude	0 to 2,000 m (0 to 6,561 feet)
Vibration	0.21 G maximum, 5 Hz to 500 Hz

#### NOTE

Above environmental requirements are NOT for the specifications and measurement accuracy of the meter, but for the operating environment of the meter.

### Ventilation Requirement

To ensure safety requirements, the specifications and measurement accuracy of the meter, you must keep the environmental temperature within the specified range by providing appropriate cooling clearance around the meter or, for the rack mount type, by forcefully air-cooling inside the rack housing. For more information on environmental temperature to satisfy the specifications and measurement accuracy of the meter, see the specification in the *E4982A Online Help*.

When the environmental temperature around the meter is kept within the temperature range of the operating environment specification (See Section **“Operating Environments”** on page 20), the meter conforms to the requirements of the safety standard. Furthermore, under that temperature requirement, the meter still conforms to the requirements of the safety standard even when placing the meter with cooling clearance as follows:

	Requirements
Back	≤ 180 mm
Sides	≤ 60mm (both right and left)

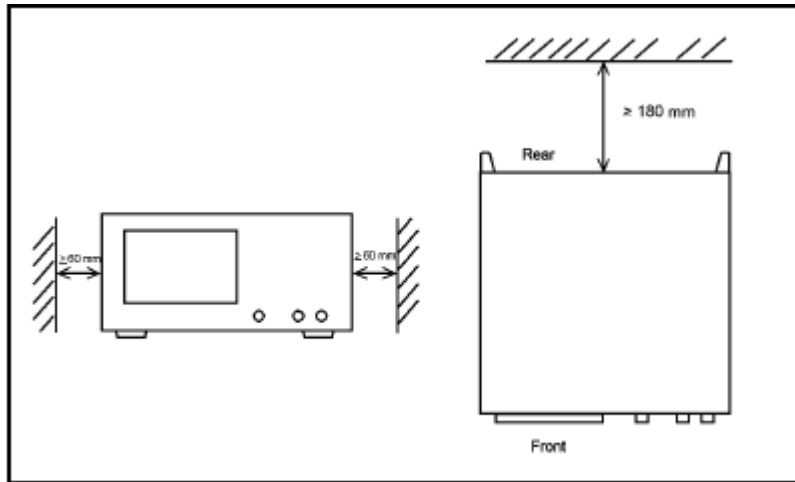

e4982a001

**Figure 1** Ventilation space at the installation

**NOTE**

Place the E4982A in a proper position as show in **Figure 1**.

**Protection Against Electrostatic Discharge (ESD)**

Set up a static-safe work-station to protect the electronic components from the damage by the electrostatic discharge (ESD) as shown in **Figure 2**.

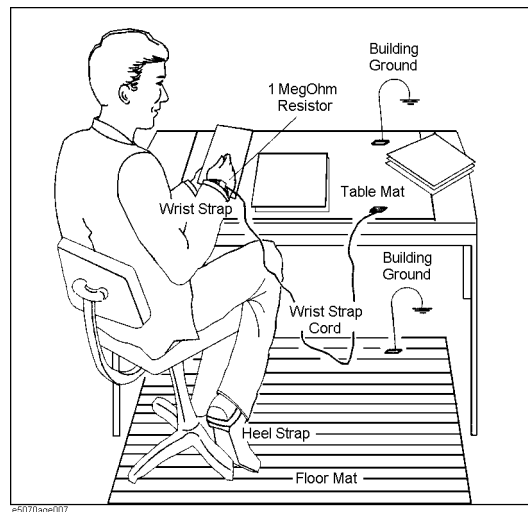

**Figure 2** Example of the static-safe work station

## Ensuring Adequate Free Space around Meter for Immediate Disconnection of Power Cable in Case of Emergency

As described in [“Disconnection from Supply Source” on page 36](#), the power supply is disconnected by removing the power cable’s connector plug from either the AC outlet or the E4982A unit. When installing the E4982A, ensure that there is sufficient free space around the unit to permit quick disconnection of the plug (from AC outlet or E4982A unit) in case of emergency.



## Installing Front Handles/Rack Mounting Flanges

The E4982A can be installed on a workbench or in a rack. This section describes how to install the front handles (Option 1CN) used for moving or transporting the instrument, and how to install the meter in an equipment rack as part of a measurement system (Option 1CM: without the handles, Option 1CP: with the handles).

**Table 1** Keysight E4982A handles/rack mounting options

Option	Name	Keysight Part Number
1CN	Handle Kit	5063-9229
1CM	Rack-mount Kit	5063-9216
1CP	Rack-mount and Handle Kit	5188-4430

**Table 2** Contents of each option

Option	Contents	Quantity
1CN	Front Handles	2
	Screws	6
	Trim Strips	2
1CM	Rack-mounting flanges (locking side plate)	2
	Screws	6
1CP	Rack-mounting flanges (locking side plate)	2
	Front Handles	2
	Screws	8

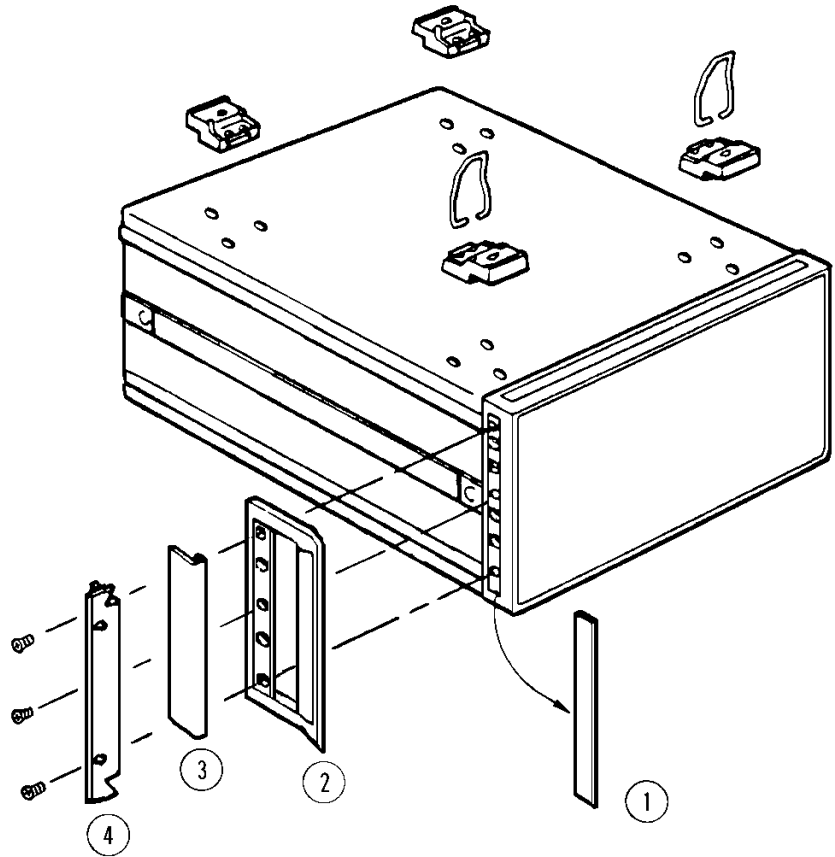

e5070aqj009

**Figure 3** Installing front handle/rack-mount kits

### How to Install the Handle Kit (Option 1CN)

The handle kit is used for transport and relocation of the E4982A. While referring to **Figure 3** install the handle kit by following these steps.

**Step 1.** Remove the adhesive-backed trim strip (1) from each side of the outer frame of the E4982A front panel.

**Step 2.** Use the screws provided screws to mount the front handles (2) on each side of the E4982A front panel frame.

**Step 3.** Attach the modified trim strip (3) provided to each front handle in order to cover the front panel locking screws.

**WARNING**

If the installed front handle becomes damaged, replace it with a new one immediately. A damaged handle can break while moving or lifting the instrument and cause personal injury or damage to the instrument.

---

### How to Install the Rack-mount Kit (Option 1CM)

The rack-mount kit includes two flanges (locking side plates) for mounting the E4982A on a rack (482.6 mm/19 inches) conforming to the EIA Standard. While referring to **Figure 3**, install the rack-mount kit by following these steps.

**Step 1.** Remove the adhesive-backed trim strip (1) from each side of the outer frame of the E4982A front panel.

**Step 2.** Use the screws provided to mount a rack-mounting flange (4) on each side of the E4982A front panel frame.

**Step 3.** Remove the four bottom feet of the E4982A (lift the bar marked TAB on the inner side of the foot and slide the foot toward the bar).

**Step 4.** Mount the E4982A on the rack.

### How to Install the Rack-mount and Handle Kit (Option 1CP)

The rack-mount and handle kit includes both the rack-mounting flanges (locking side plates) and front handles. While referring to **Figure 3**, install the rack-mount kit by following these steps.

**Step 1.** Remove the adhesive-backed trim strip (1) from each side of the outer frame of the E4982A front panel.

**Step 2.** Use the screws provided to mount a front handle (2) and rack-mounting flange (4) on each side of the E4982A front panel frame.

**CAUTION**

Use both a front handle and a rack-mounting flange in the same time certainly. Do not attempt to install flanges or handles separately with hardware provided. Serious electrical damage will occur to the instrument.

---

## 1 Installation

**Step 3.** Remove the four bottom feet of the E4982A (lift the bar marked TAB on the inner side of the foot and slide the foot toward the bar).

**Step 4.** Mount the E4982A on the rack.

## Connecting Test Head

### Connecting the DUT when using a special test fixture

When taking measurements while using special test fixtures with 7-mm terminals like the Keysight 16196A, follow these steps to connect the test head, test fixture stand, and 3.5-mm-to-7-mm adapter.

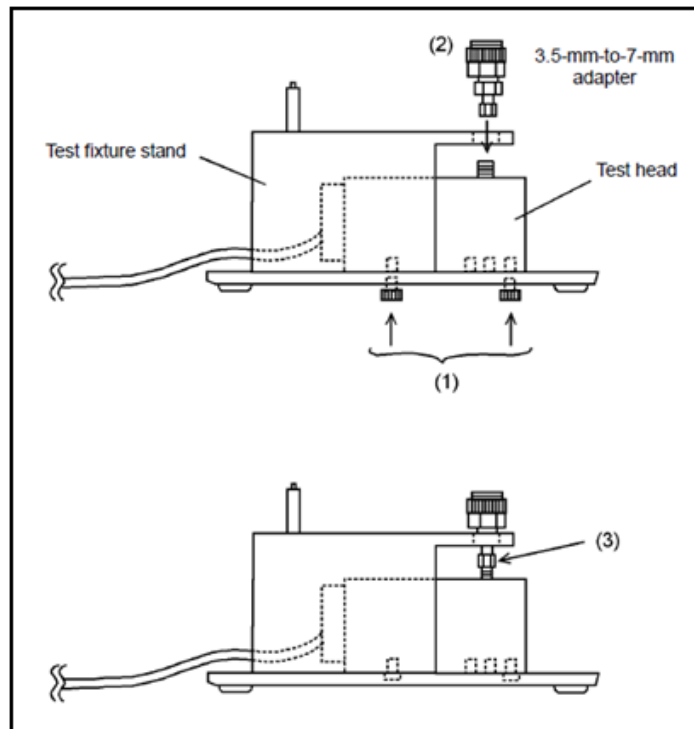

e4982a002

**Figure 4** Connecting the test head to test fixture stand

**Step 1.** As shown in **Figure 4** (1), attach the test head to the fixture stand with two screws. At this point, do not tighten the screws completely (there should be some play).

**Step 2.** As shown in **Figure 4** (2), align the 3.5-mm-to-7-mm adapter with the hole in the test fixture stand and gently insert the adapter.

**Step 3.** As shown in **Figure 4** (3), tighten the connector nut of the 3.5-mm connector with the provided wrench (for 3.5mm/SMA connector).

**NOTE**

Be sure to use the provided wrench (for 3.5-mm/SMA connector) when tightening the connector nut of the 3.5-mm connector. Using another wrench could result in damage to the connector, which would cause incorrect measurements in the future.

---

**Step 4.** Firmly tighten the two screws shown in [Figure 4](#) (1).

**Step 5.** Attach the three N(m)-SMA(f) adapters to the RF OUT, PORT 1, and PORT 2 terminals of the E4982A test head interface.

Connect the three SMA(m) connectors (RF OUT, PORT1, PORT 2) of the test head cable to the SMA(f) terminals of the adapters attached in Step 5. Then tighten each of the connectors using the provided wrench (for 3.5-mm/SMA connector) ([Figure 5](#)).

**NOTE**

Be sure to use the provided wrench (for 3.5-mm/SMA connector) when tightening the connector nut of the 3.5-mm connector. Using another wrench could result in damage to the connector, which would cause incorrect measurements in the future.

---

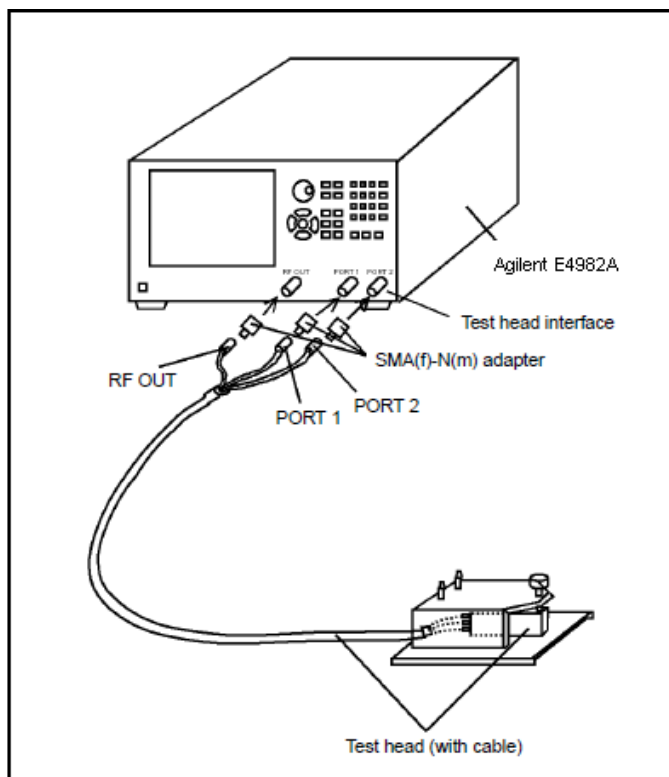

e4982a003

**Figure 5** Connecting test head cable to E4982A

### When using the test head fixed on a handler, etc.

The test head can be attached to a handler or other automatic equipment instead of using a special test fixture. In this case, secure the test head to the device using the four screw holes provided in the test head as appropriate. Connect the suitable cable, connectors, test fixture, etc. for connection of the DUT to the 3.5-mm terminal of the test head.

#### NOTE

To minimize additional error in measurement, the distance from the test head's 3.5-mm terminal to the DUT connection side should be kept as short as possible.

## 1 Installation

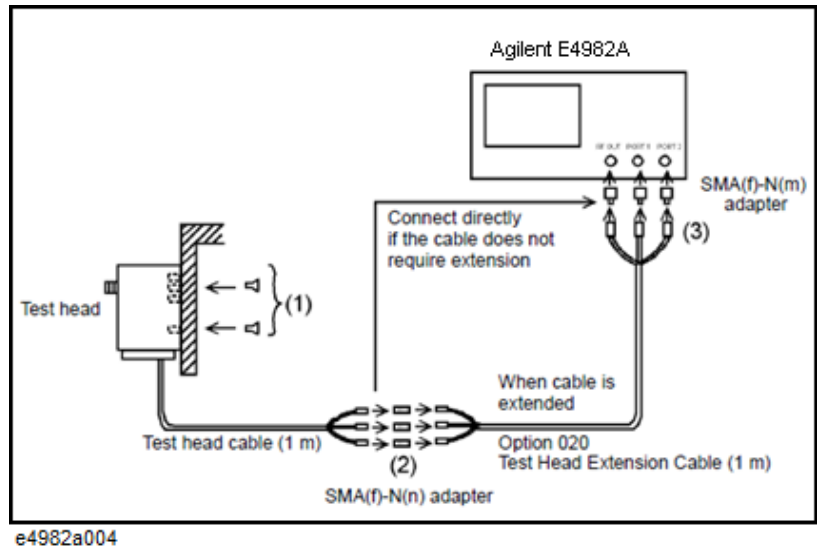

**Figure 6** Attaching test head to a handle, etc.

**Step 1.** Use one or more of the four screw holes in the test head to secure the test head to a handle or other appropriate location (Figure 6 (1)).

**Step 2.** Connect the 1-m cable already connected to the test head to the optional 020 Test Head Extension Cable (1m) if the original length is insufficient (Figure 6 (2)).

**Step 3.** Connect the three N-type connectors (RF OUT, PORT 1, PORT 2) at the end of the cable to the respective test head interfaces (RF OUT, PORT 1, PORT 2) on the front panel of the E4982A (Figure 6 (3)).

### Caution for connecting the SMA connector to the test head connector

Do not rotate the cable to connect the SMA(male) connector to the test head. Rotating the cable may cause damage to the cable's center conductor. Be sure to rotate the connector nut to connect the SMA cable.



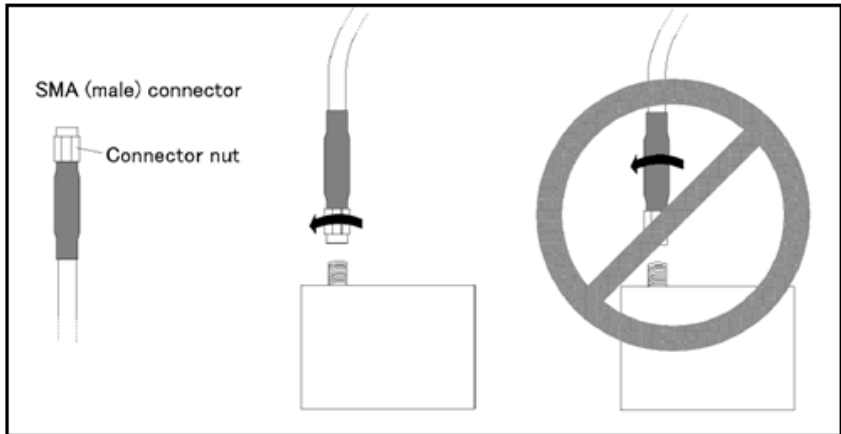

e4982a005

**Figure 7** Attaching test head to a handle, etc.

## **Connecting Mouse and Keyboard**

The E4982A allows you to connect Mouse and/or keyboard through USB. USB mouse and keyboard can be connected with the USB ports on the front or rear panels.

Initial registration of the E4982A requires the mouse and keyboard before turning on the power.

## Power Supply

Before turning on the E4982A power, check the following.

### Verification of the Power Supply

Confirm that the power supplied to the E4982A meets the following requirements:

	Requirements
Voltage	90 to 264 VAC ( $V_{\text{peak}} > 120 \text{ V}$ )
Frequency	47 to 63 Hz
Maximum power consumption	300 VA

### Verification and Connection of Power Cable

The three-wire power cable attached to the E4982A has one wire serving as a ground. Using this power cable allows the E4982A to be grounded, thereby protecting you against electrical shock from the power outlet.

**Step 1.** Confirm that the power cable is not damaged.

#### **WARNING**

**NEVER use a power cable showing any sign of damage. Faulty cables can cause electrical shock.**

---

**Step 2.** Use the supplied cable to connect between the power cable receptacle ([Figure 8 on page 36](#)) on the rear panel of the E4982A and a three-wire power outlet with the grounding prong firmly connected in the ground slot.

#### **WARNING**

**Use the supplied power cable with grounding wire to securely ground the E4982A.**

---

Power cord list, 16000-99101 shows the power cable options.

## Blown Fuses

If the fuse appears to have blown during operation, this instrument may be subject to failure and must be repaired. For any assistance, contact Keysight Technologies Customer contact center listed at the end of this guide.

The product uses the following fuse types:

UL/CSA Type, Slow-Blo, 10 A-250 Vac.

**WARNING**

**DO NOT replace the fuse yourself; doing this may expose you to electrical shock.**

---

## Starting the E4982A

This section describes how to turn on/off the E4982A power and how to cut off the power supply in an emergency.

### Turning the Power ON and OFF

The standby switch can turn/off the E4982A. The color on the button shows the status, as shown below:

Indicator Color	Description
Green	Normal power on status
Orange	Standby status
Red	Illegal power on status

Perform the following steps to turn the power ON or OFF.

#### Turning the Power ON

**Step 1.** Confirm if the Line Switch on the rear panel is on. The switch should always be turned on.

**Step 2.** Press the standby switch once and it changes to green color.

This operation turns ON the power, and the E4982A starts the self-test.

**Step 3.** Confirm that the self-test indicates normal operation.

Normal operation is confirmed by the self-test if no error message appears.

#### Turning the Power OFF

**Step 1.** To turn off the power of the E4982A, first, press this standby switch or send a shutdown command from the external controller to activate the shutdown process (the process of software and hardware necessary to turn off the power supply). This puts the E4982A into the standby state and the button changes to orange color.

**Step 2.** Next, if necessary, turn off power supply to the power cable receptacle (Line Switch) on the rear panel.

## NOTE

Under normal use, **never directly interrupt the power supply to the power cable receptacle on the rear panel when the power supply is on.** Always keep the Line Switch ON and never turn it.

If you directly interrupt the power supply to the power cable receptacle when the power supply is on, or turn off the Line Switch, the shutdown process will not work. This could damage the software and hardware of the E4982A and lead to device failure.

Turning on the power supply after a faulty shutdown may cause the system to start up in a condition called "safe mode." If this occurs, first shut down the system to set it to the standby state and then turn on the power supply again to start up the system in normal mode.

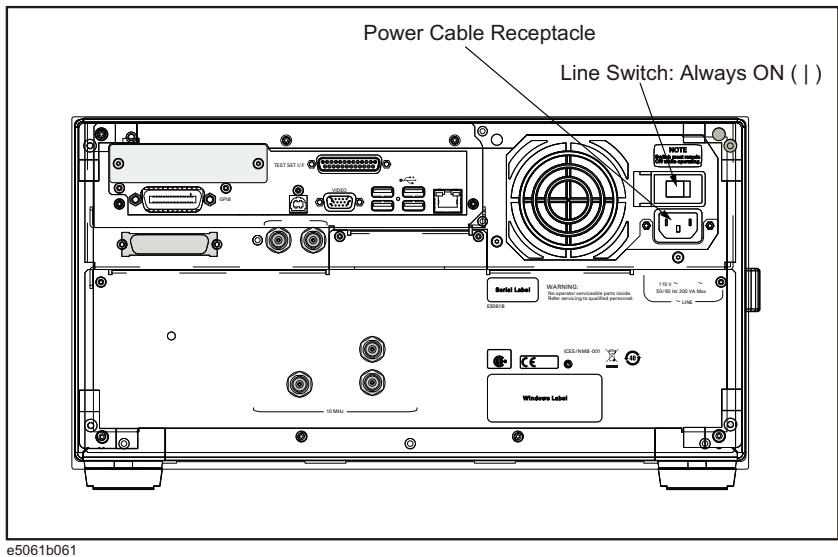

**Figure 8** Line switch (Always ON) and power cable receptacle

## Disconnection from Supply Source

The power supply of the E4982A is cut off by disconnecting the plug of the power cable (on either AC outlet side or E4982A side). When it is necessary to disconnect the power supply in order to avoid shock hazards, etc., pull out the power cable plug from either the AC outlet side or the E4982A side.

**NOTE**

To allow this operation to be performed smoothly, be sure to follow the guidelines in ["Ensuring Adequate Free Space around Meter for Immediate Disconnection of Power Cable in Case of Emergency"](#) on page 22.

When turning the power OFF under normal circumstances, always follow the methods described in ["Turning the Power OFF"](#) on page 35.

---

## **Initial Registration of E4982A**

When you start up the E4982A for the first time, you need to perform the initial registration of the Windows XP operating system of the E4982A.

**NOTE**

You cannot use the front panel keys during the initial registration of the E4982A therefore connect the mouse and the keyboard before turning on the power.

---

**NOTE**

If you perform the following procedure incorrectly, a message will prompt to give you option to return to the previous registration screen and perform the registration. In such case, follow the instruction to return to the previous registration screen.

---



**Step 1.** Turn on the E4982A. Do not touch any key on the front panel during boot up.

**Step 2.** The screen as shown in the **Figure 9** appears. Select **Windows XP Professional** and press **[Enter]**.

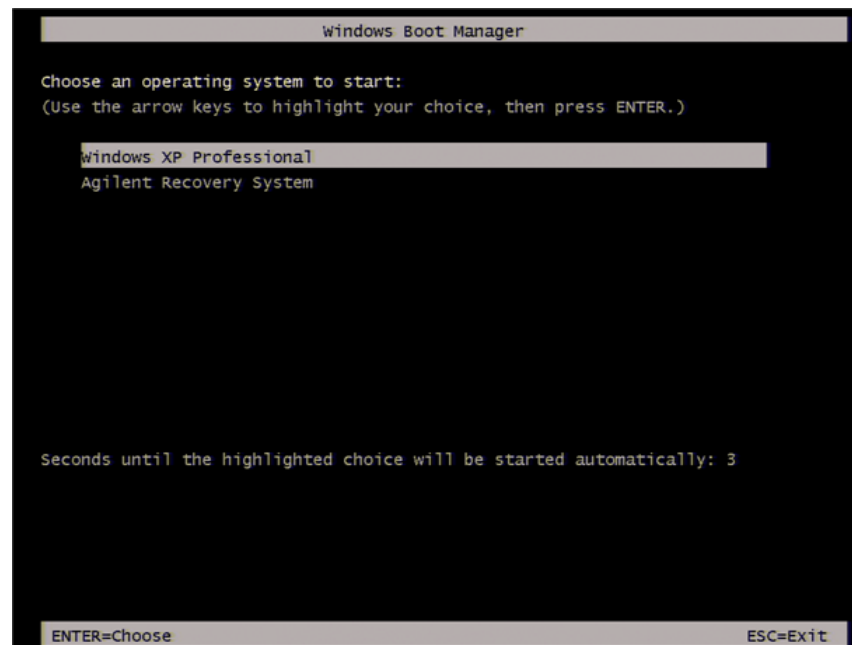

**Figure 9** System start up screen (1/3)

**NOTE**

After several seconds, the next screen appears automatically even if you do not press any key.

## 1 Installation

**Step 3.** The screen as shown in the **Figure 10** appears. Press **[Enter]**.

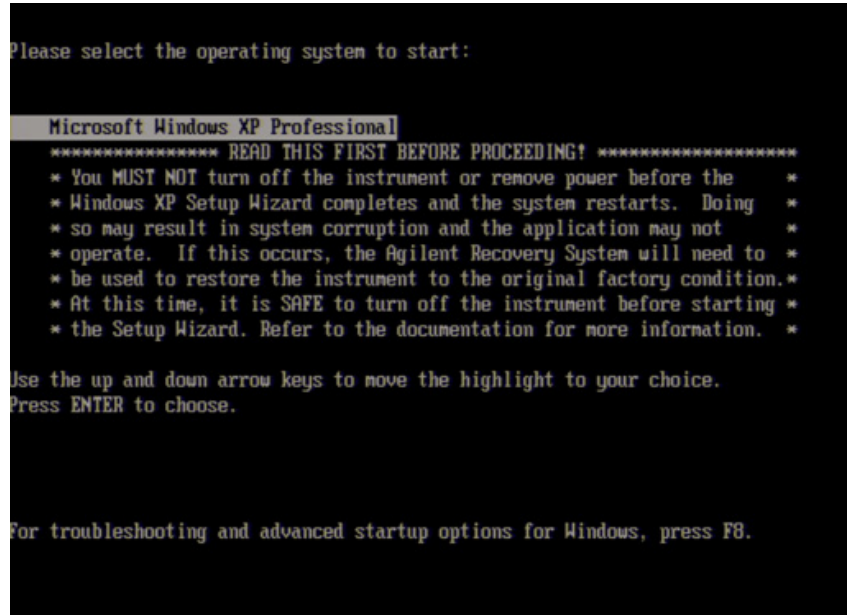

**Figure 10** System start up screen (2/3)

**Step 4.** The windows start up screen as shown in **Figure 11** appears.

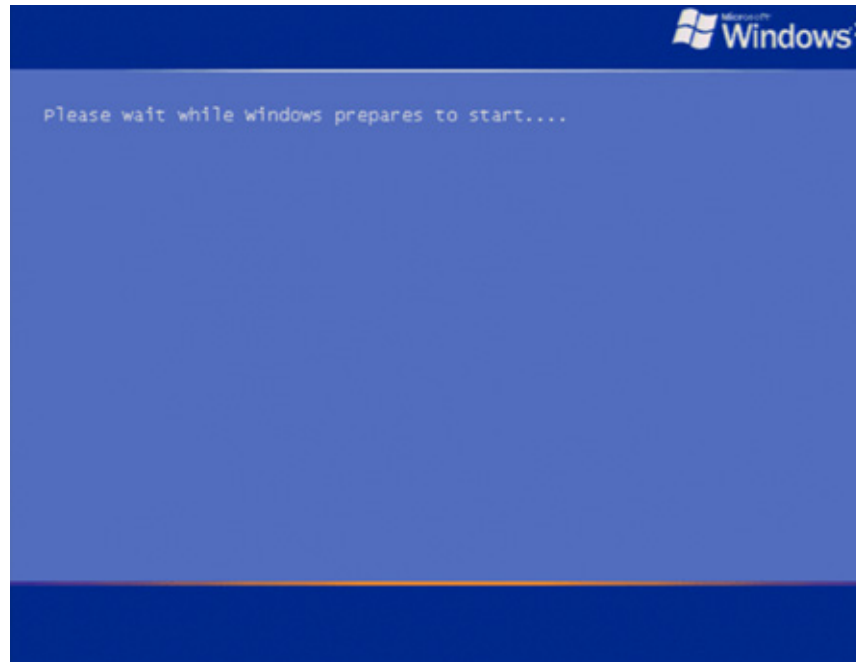

**Figure 11** System start up screen (3/3)

## 1 Installation

**Step 5.** In the License agreement dialog box, select the **I accept this agreement** box and click the **Next >** button. **Figure 12** shows the license agreement dialog box in Windows XP Pro for Embedded Systems.

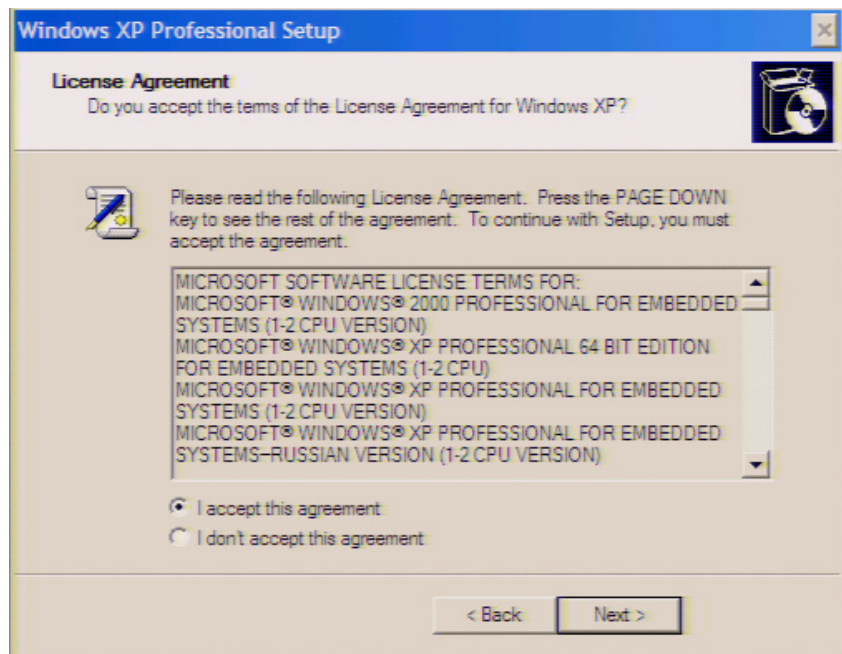

**Figure 12** License agreement dialog box

**Step 6.** In the next dialog box, set the date and time for your Windows. Then, click the **Next>** button (Figure 13).

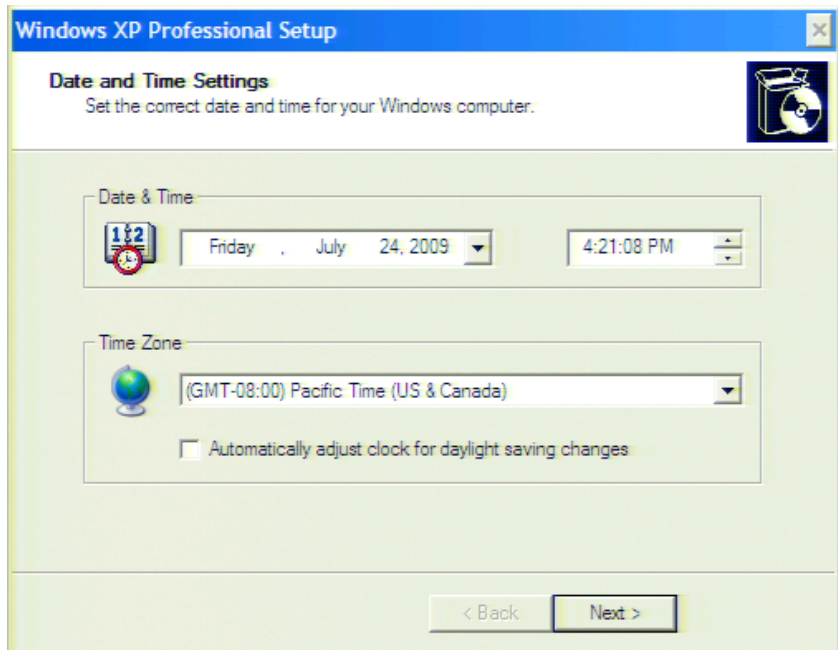

**Figure 13** Date and Time Setting dialog box

**Step 7.** After a while, the E4982A restarts automatically.

## Calibration of the Touch Screen

When E4982A measurement screen appears, you have to calibrate the touch screen. Follow the procedure described below to calibrate the touch screen.

**Step 1.** Press **System** .

**Step 2.** Press **Service Menu**.

**Step 3.** Press **Test Menu**.

**Step 4.** Press **Adjust Touch Screen**.

The touch screen calibration screen (**Figure 14**) appears.

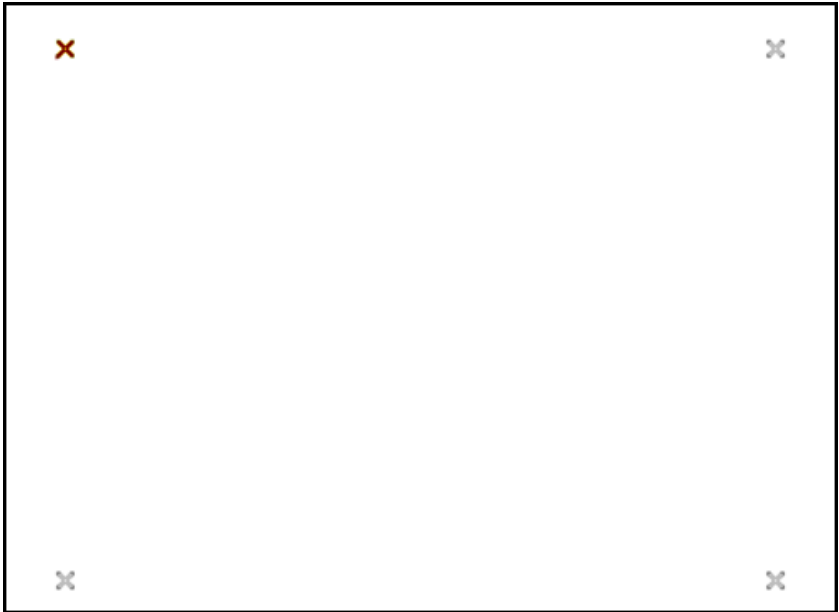

e4982a006

**Figure 14** Touch Panel Calibration Screen

**Step 5.** Touch the symbol on the upper left of the screen with your finger. The symbols also appears on the upper right, lower left, and lower right of the screen. Touch all the symbols in that order with your finger.

Touching all the four locations described above with your finger automatically concludes the touch screen calibration.

**NOTE**

If you do not start to perform the touch screen calibration within several seconds, the previous measurement screen re-appears automatically.

---

## **1 Installation**



## **2 E4982A Troubleshooting**

Troubleshooting during Startup	48
System Recovery	49

This chapter describes the troubleshooting process during start up and the procedure of the operating system (OS) recovery when the Windows XP OS has been damaged.

## Troubleshooting during Startup

When you encounter problems during start up, see [Table 3](#). System recovery saves most of problems.

**Table 3** Troubleshooting during startup

Symptom	Solution
Turning on ( ) the standby switch does not start up the system.	Confirm that the power cable is properly plugged in. Confirm that the line switch at the rear panel is turned on.
The system starts up, but it automatically shuts down immediately.	Execute the system recovery.
The system starts up, but it enters the service mode (The status bar at the lower right of the screen displays <b>SVC</b> in red).	

## System Recovery

By executing system recovery, you can return the E4982A's system (the Windows operating system and the firmware) to the factory state (at the time of purchase<sup>\*1</sup>).

### CAUTION

Strictly follow the steps described below. If you do any operation other than the following steps, the system may not be recovered.

---

### Notes on executing the factory recovery function

Executing the factory recovery function causes the following conditions:

- In addition to the Windows operating system and the firmware, the following settings of the E4982A are returned to the factory state.
  - Network setting
  - GPIB setting
- You need to execute initial registration again.

Files that you have created using the save function (files in the D drive) are not affected. However, Keysight recommends backing them up before executing system recovery for precautionary purposes. For more information on backup, refer to *"Backing Up the Data"* as described in *E4982A Online Help*.

### Procedure to execute the factory recovery

This section describes how to return the contents of the C drive to the factory state.

### NOTE

You need a keyboard for this operation.

---

**Step 1.** Shut down the E4982A.

\* 1. The default setting of the hard disk is recovered during the system recovery. For the hard disk that had failed earlier and had been replaced (after purchase), its default setting may not be the same as the factory state.

- Step 2.** Disconnect all of the USB device from the USB ports.
- Step 3.** Connect the keyboard to the E4982A.
- Step 4.** Press the standby switch of the E4982A to turn it on.
- Step 5.** When the screen as shown in the figure below appears, select **Keysight Recovery System** and press [Enter].

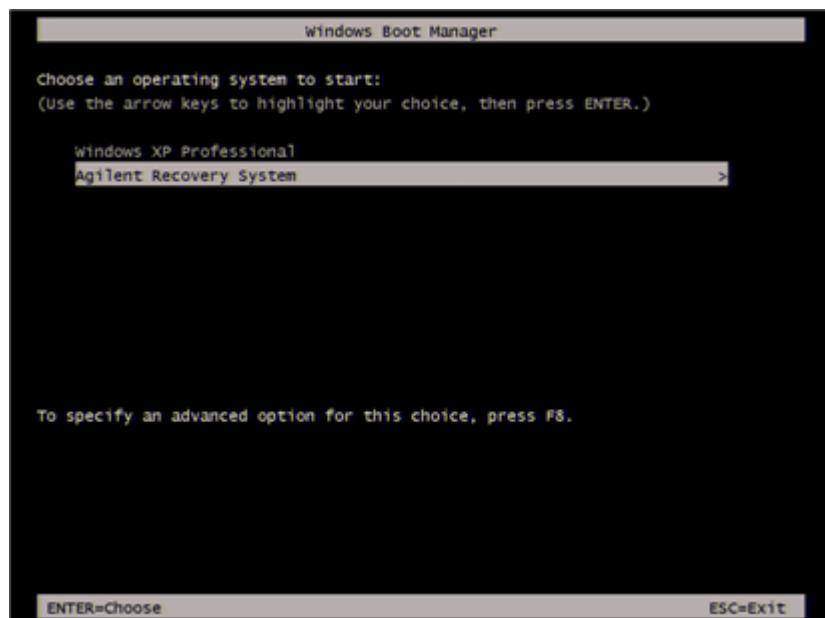
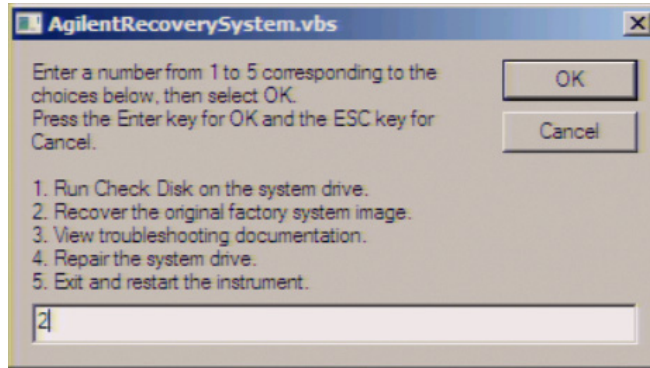

**Figure 15** Keysight Recovery System selection screen

### NOTE

After several seconds, the next screen appears automatically even if you do not press any key.

**Step 6.** Type **2** to select **Recover Factory Backup Image** option and press **[Enter]**.



**Figure 16** System recovery selection screen

**Step 7.** A confirmation message appears. Click **OK** to continue the process.

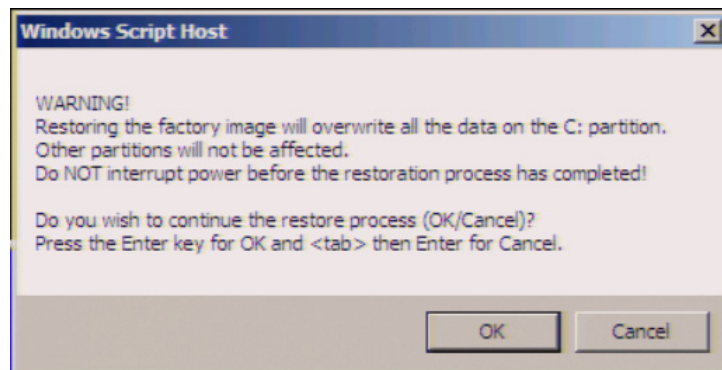

**Figure 17** System recovery confirmation screen

## 2 Troubleshooting

**Step 8.** The progress of the system configuration is displayed on the screen. The recovery takes a few minutes depending on the amount of data.

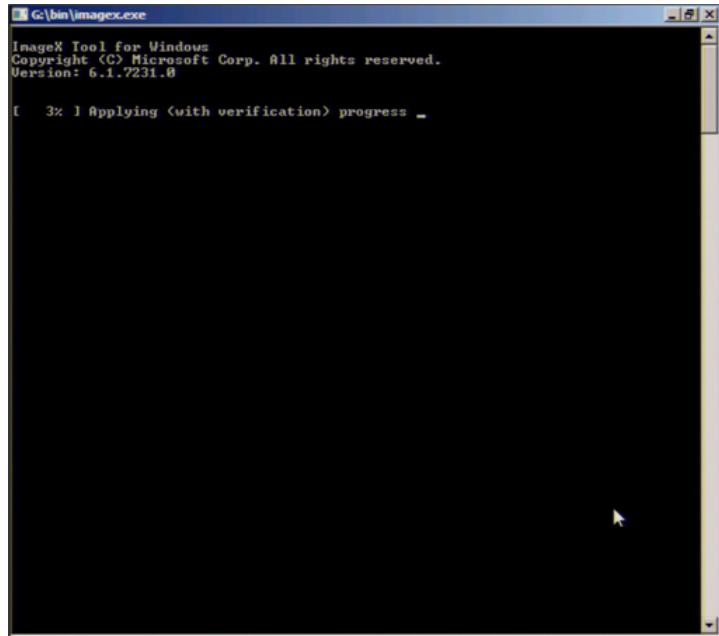

**Figure 18** System configuration progress screen

**Step 9.** Once the recovery process is completed, completion message prompts. Click **OK**. The E4982A restarts automatically.

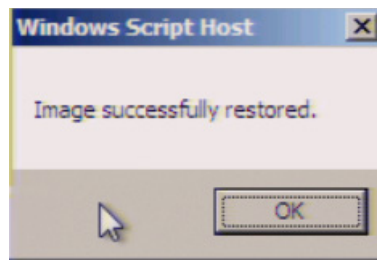

**Figure 19** Recovery Option confirmation dialog box

**Step 10.** Type 5 to select **Exit and Restart the instrument** and press **[Enter]**.

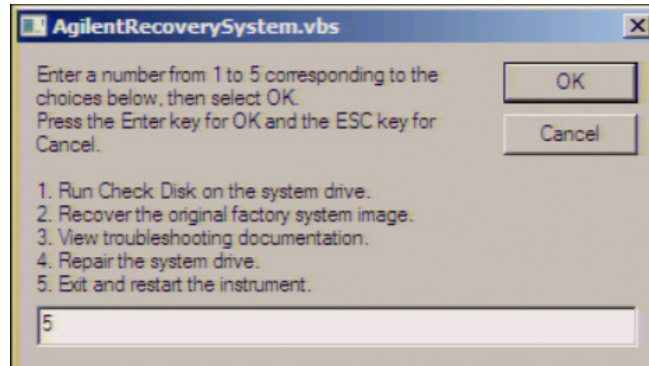

**Step 11.** After the restart, execute initial registration. For information on the execution procedure, refer to [“Initial Registration of E4982A”](#) on page 38.

**Step 12.** Execute the calibration of the touch screen. For information on the execution procedure, refer to [“Calibration of the Touch Screen”](#) on page 44.

**CAUTION**

Never turn off the power during the system recovery because doing so may cause serious damage to the E4982A.

## **2 Troubleshooting**



# Index

## A

assistance, 11

## C

connection  
connecting mouse and keyboard, 32

## D

documentation warranty, 11

## E

E4982A  
starting the E4982A, 35  
environmental requirements  
operating environments, 20  
ventilation requirement, 20  
error-correction  
temperature range, 20  
exclusive remedies, 11

## F

front handles  
how to install front handles, 23  
how to install the handle kit, 23

## H

handle and rack-mount kit  
how to install the rack-mount and handle  
kit, 25  
handle kit  
how to install the handle kit, 24

## I

initial registration, 32, 38  
inspection  
checking the shipment, 18

## K

Keysight Technologies sales and service office  
regional sales and support offices, 57  
shipping consideration due to breakdown,  
etc., 9

## M

manual  
contents, 14

## O

option

Option 1CM, 23, 25  
Option 1CN, 23, 24  
Option 1CP, 23, 25

## P

power  
disconnection from supply source, 36  
power cable options, 33  
turning the power ON and OFF, 35  
verification and connection of power  
cable, 33  
verification of the power supply, 33

## R

rack-mount and handle kit  
how to install the rack-mount and handle  
kit, 25  
rack-mount kit  
how to install the rack-mount kit, 25

## S

safety  
symbols, 10  
shutdown  
turning the power OFF, 35  
system  
installing rack mounting flanges, 23  
System Recovery  
how to execute factory recovery, 49



## Regional Sales and Support Offices

For more information about Keysight Technologies test and measurement products, applications, services, and for the current sales office listing, visit our web site: <http://www.keysight.com/find/tmdir>. You can also contact one of the following centers and ask for a test and measurement sales representative<sup>\*1</sup>.

**United States:**

Test and Measurement Call Center  
(tel) 1 800 452-4844  
(fax) 1 888 900-8921

**Canada:**

Test and Measurement Call Center  
(tel) 1 877 894-4414  
(fax) 1 888 900-8921

**China:**

(tel) 800 810-0189  
(fax) 800 820-2816

**Europe:**

(tel) (31 20) 547-2323  
(fax) (31 20) 547-2390

**Japan:**

Call Center  
(tel) 0120 421-345  
(tel) (81) 426 56-7832  
(fax) (81) 426 56-7840

**Korea:**

(tel) (82 2) 2004-5004  
(fax) (82 2) 2004-5115

**Latin America:**

(tel) (305) 269-7500  
(fax) (305) 269-7599

**Taiwan:**

(tel) 0800 047 866  
(fax) 0800 286 331

**Australia/New Zealand:**

(tel) (61 3) 9210-5555 (Australia)  
(fax) (61 3) 9210-5899  
(tel) (64 4) 939-0636 (New Zealand)  
(fax) (64 4) 972-5364

**Asia Pacific:**

(tel) (65) 6375-8100  
(fax) (65) 6836-0252  
E-mail: [tm\\_asia@keysight.com](mailto:tm_asia@keysight.com)

\* 1. As of 21/01/04





This information is subject to change without notice.  
© Keysight Technologies 2012, 2015  
Edition 2, February 2015



E4982-90000  
[www.keysight.com](http://www.keysight.com)